



SUSTAINING OPERATIONS IN A COVID-19 WORLD AND BEYOND

Thursday 4 February 2021
14h00-15h00 CET

WEBINAR IN COLLABORATION WITH IRO

WORLDWIDE REACH. HUMAN TOUCH.



SPEAKERS

INTERNATIONAL
SOS



DR LARS PETERSEN

REGIONAL MEDICAL DIRECTOR, INTERNATIONAL SOS



**SIGBJORN DALANE, HEALTH & WORK ENVIRONMENT MANAGER
NEPTUNE ENERGY**



**JEROEN SMITS, GLOBAL HSSE MANAGER
FUGRO**



AGENDA



SITUATION UPDATE (Dr Lars Petersen, International SOS)

- Current COVID-19 situation globally and specifically in Offshore & Maritime
- How do ongoing developments impact organisations, how to sustain operations?

GAME CHANGERS

- Vaccinations & testing
- COVID passports

STAFF HEALTH & MENTAL WELLBEING How can you make sure you keep your people (mentally) healthy and safe?

BUSINESS TRAVEL – LOOKING AHEAD

CASE STUDY 1 – NEPTUNE ENERGY (Sigbjorn Dalane)

CASE STUDY 2 – FUGRO (Jeroen Smits)

Q & A (All)

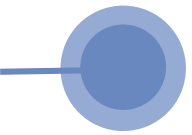

COVID-19 SITUATION UPDATE

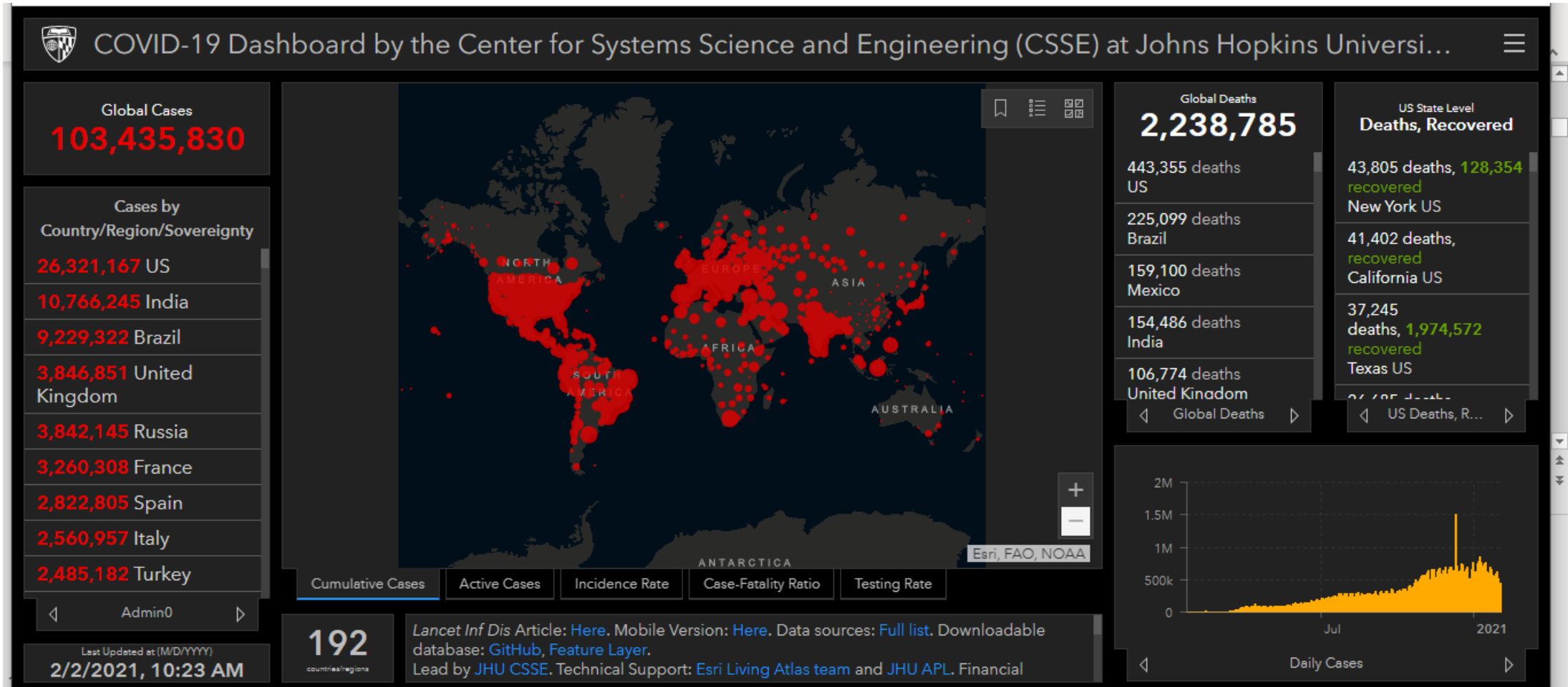

GLOBAL EVOLUTION OF THE PANDEMIC



Daily deaths of patients diagnosed with coronavirus (7-day rolling average)

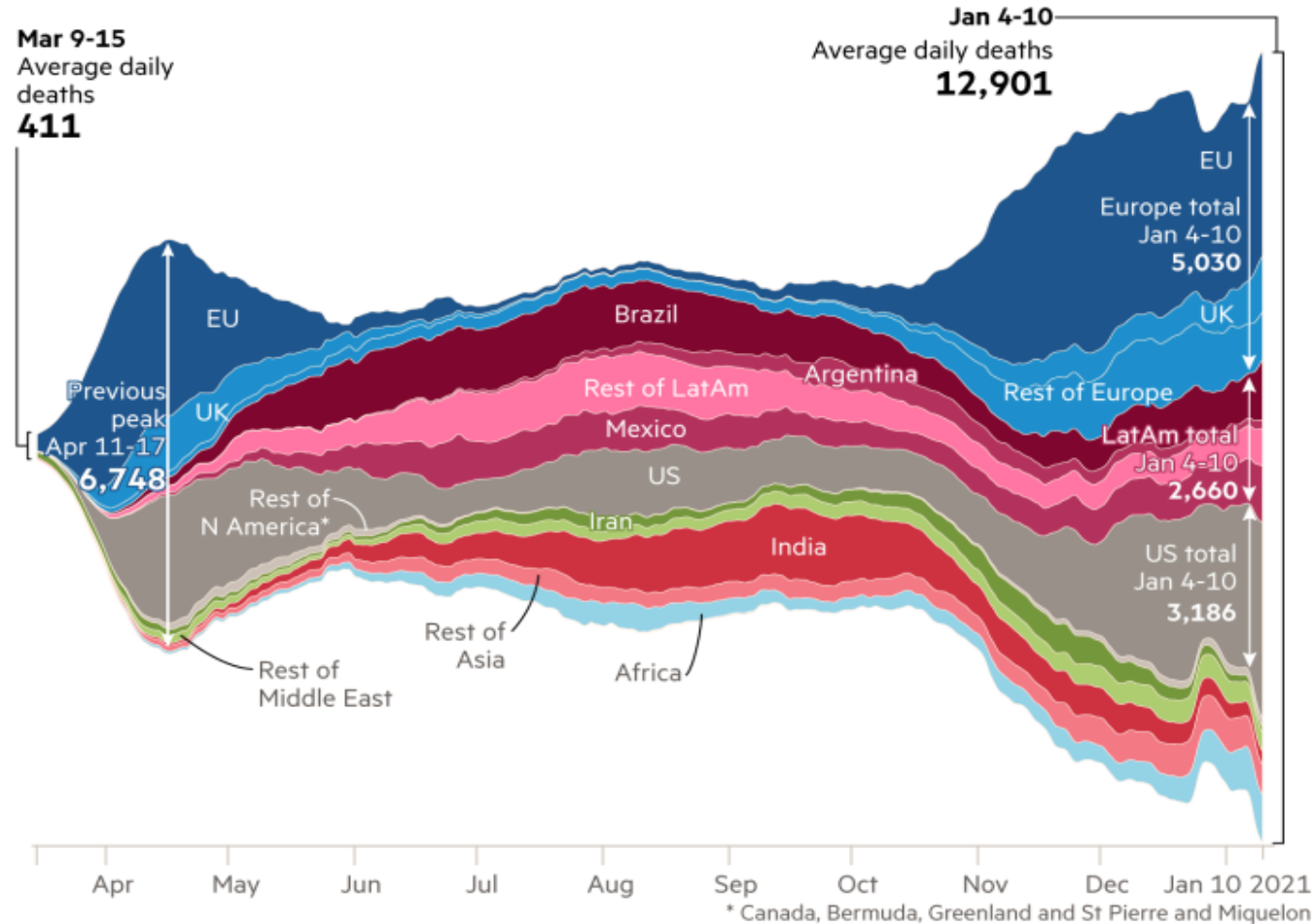

SARS-COV-2 VARIANTS

Mutant B1.1.7 (UK + many countries)

R0 base: 2.3-2.6 -> adds an extra 0.4-0.7

UK data: transmissibility increased ~ 56%?

Are <20 years age more exposed?

Increase in severity ~30%?

Mutant B1.351 (South Africa + others)

Transmissibility increased ~50%

Can it evade immune system better?

+ Mutant P1 (Brazil/Japan + others)

+ California

+ Others

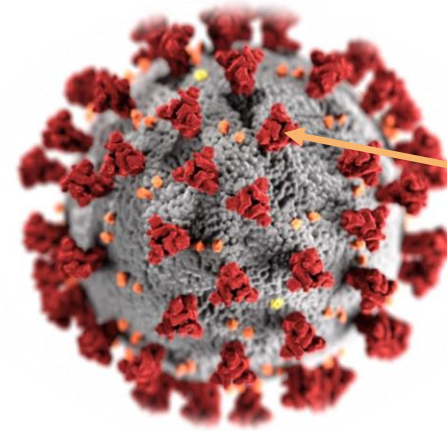

Spike Protein

HEALTH AND SCIENCE

Moderna says it's working on Covid booster shot for variant in South Africa, says current vaccine provides some protection

PUBLISHED MON, JAN 25 2021:8:29 AM EST | UPDATED MON, JAN 25 2021:9:16 AM EST



COVID-19 SITUATION UPDATE – OFFSHORE & MARITIME

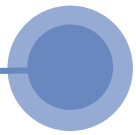

VESSEL JOINING INSTRUCTIONS: HOW TO REDUCE OPERATIONAL DISRUPTION



TESTING

- Ensure workers have been tested prior to joining the vessel

DISTANCING

- Ensure a distance of at least 6 feet / 2 meters is maintained between employees
- Do not gather in groups
- Stay away from crowds

PERSONAL HYGIENE

- Maintain good personal hygiene
- Keep some distance from people who are obviously sick
- Sanitize and wash hands frequently
- Provide sanitizer available all over the vessel



MANAGING (SUSPECTED) CASES ON BOARD

- Rapid PCR testing
- Isolation
- Disembarkation
- Contact tracing – testing - quarantine



COVID-19 TESTING



PCR Testing –
Standard



Gold
Antigen Rapid
Diagnostic Testing
Re-emerging

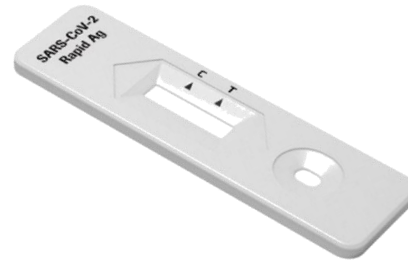

Saliva Testing

Pending further



Breath Testing

Trials under way



Antibody
Rapid Diagnostic
Testing
Specific uses
only

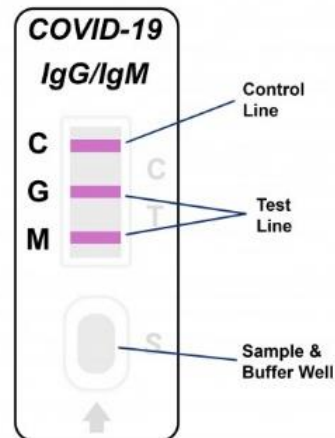

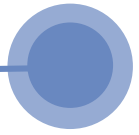

MANAGING QUARANTINE & TESTING

Testing during quarantine can reduce length from 14 to even 7 days

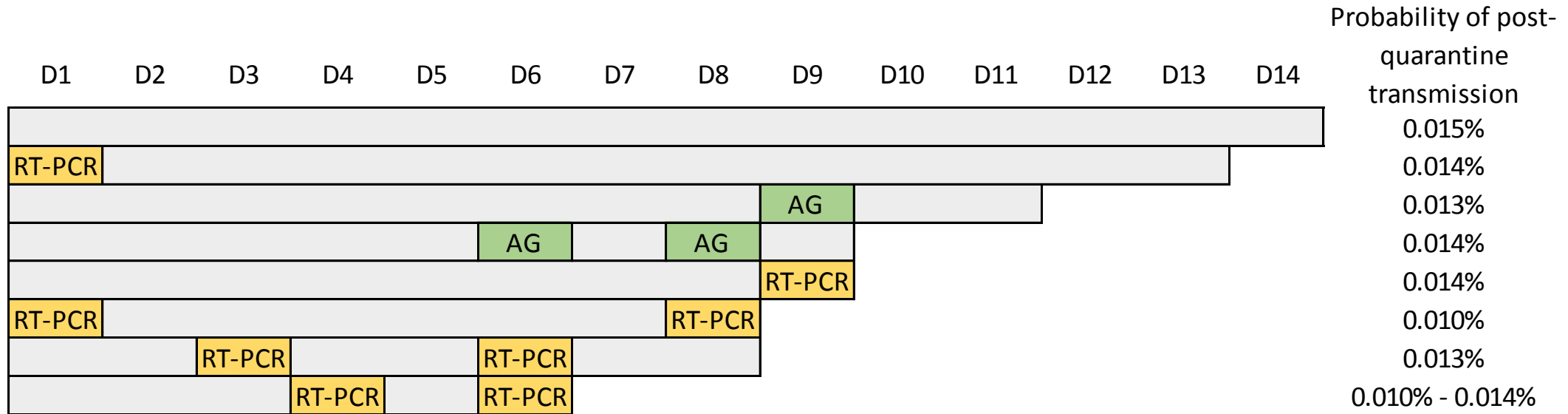

AG Rapid Antigen Test, 85% sensitivity
RT-PCR RT-PCR Laboratory Test, 95% sensitivity

ONGOING DEVELOPMENTS IMPACTING YOUR ORGANISATION

- COVID variants
- Misinformation
- Further government restrictions – quarantine hotels
- Vaccine passports
- Global distribution limitations (vaccines)
- Testing – ongoing changing requirements



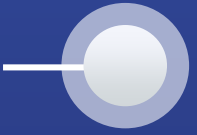

GAME CHANGERS

GAME CHANGERS TO SUSTAIN OPERATIONS

- Vaccine programs/vaccinations
- Communications to workforce
- Testing
- COVID/Health passport



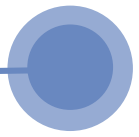















VACCINES APPROVED

(AVAILABLE TO PUBLIC)



Company	UK Approved	Type	Doses	Storage
 Oxford Uni- AstraZeneca	✓	Viral vector (genetically modified virus)	 x2	 Regular fridge temperature
 Pfizer-BioNTech	✓	RNA (part of virus genetic code)	 x2	 -70C
 Moderna	✓	RNA	 x2	 -20C
 Novavax	Pending	Protein-based	 x2	 Regular fridge temperature
 Janssen	Pending	Viral vector	 x1	 Regular fridge temperature

CHALLENGES TO CONSIDER

How long will it take?

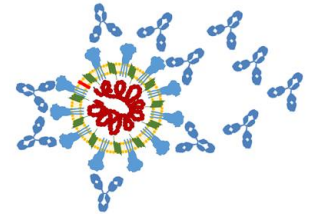
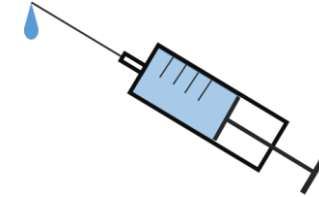
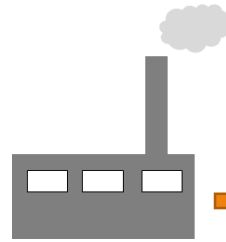

Prioritize
population

Allocation

Production

Distribution

Administration -
Ensuring uptake of
2nd dose

Monitoring
vaccine
effectiveness
and safety

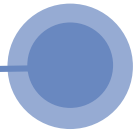

HOW TO IMPROVE VACCINATION COMPLIANCE?

Biggest risk = MISINFORMATION

- Trust
- Transparency
- Empathy
- Communication
- Equity
- Participation



Confidence in products



Confidence in providers



Confidence in policy makers and systems

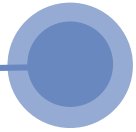

HOW CAN EMPLOYERS HELP TO SUPPORT VACCINATION ROLLOUT



ASSIST IN DEFINING GUIDELINES

- Provide communication materials on the importance of a vaccine
- Recommend the vaccine of use per country
- Create incentives to get vaccinated (e.g vaccination tracker, recognition etc)
- Request vaccine certificate (country / law specific)

PROVIDE WORKFORCE WITH THE TOOLS TO NAVIGATE THE SYSTEM

- Provide workforce with the latest information on vaccine developments
- Provide them with assistance on how to access a vaccine in their location
- Reduce logistical challenges by offering support (administrative support etc)

ASSIST WITH VACCINE PROCUREMENT

- Provide access to the vaccine through an external provider (eg nurse on site etc)
- Hold on site / office vaccination clinics
- Provide global overview of current vaccinations available
- Assist expats with access to their national health authorities recommended vaccine

MENTAL HEALTH CHALLENGES



WORLDWIDE REACH. HUMAN TOUCH.

RECENT STUDY ON MENTAL HEALTH IN ROTATIONAL OFFSHORE WORKERS

DR. RODRIGO RODRIGUEZ-FERNANDES
DR. RACHEL LEWIS
INTERNATIONAL SOS FOUNDATION



WORLDWIDE REACH. HUMAN TOUCH.

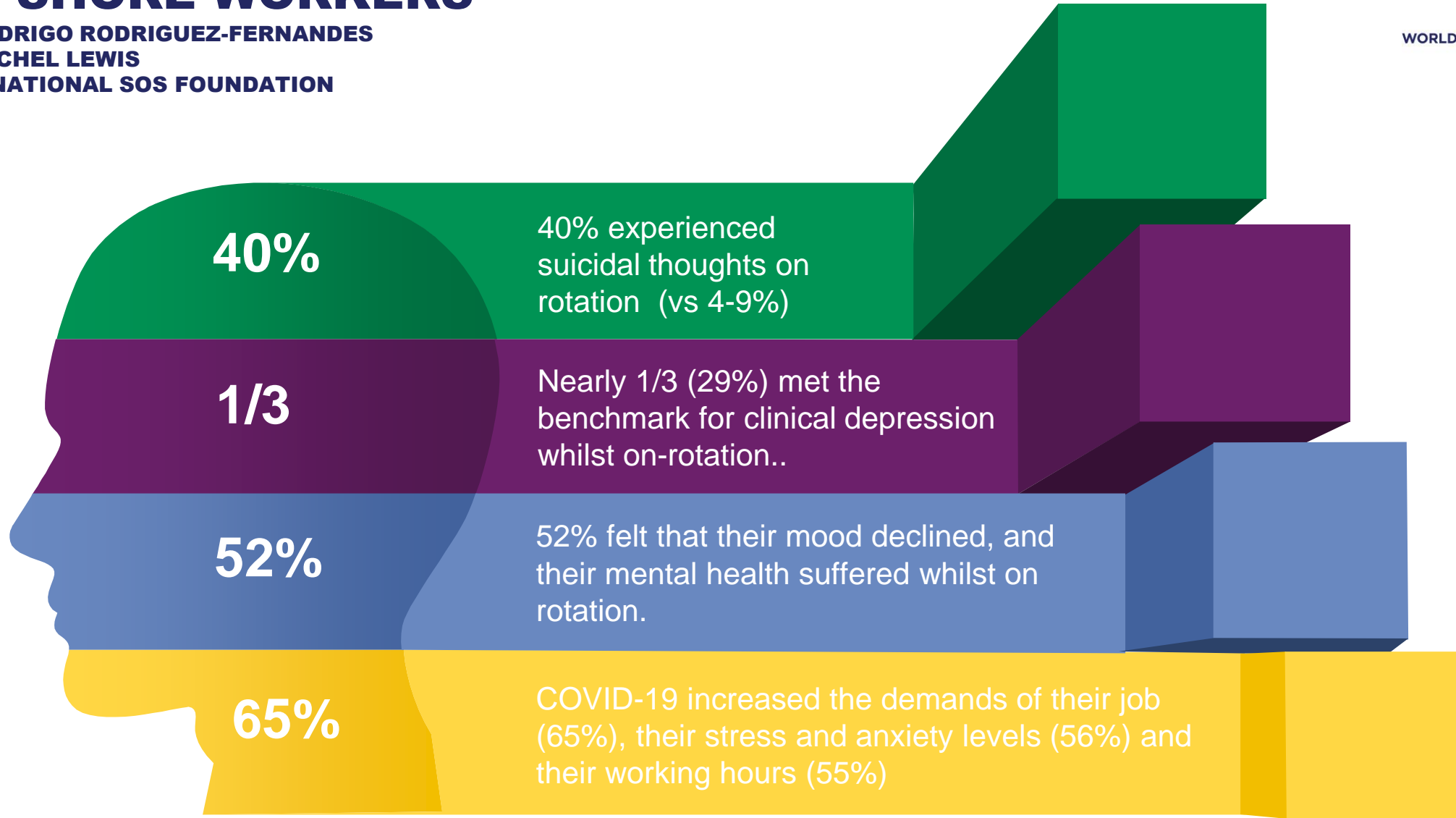

62%

When on rotation
62% had lower levels
of wellbeing than the
general population

Wellbeing

Lower general wellbeing
dropped to 31% while off
rotation

PA and Sleep

35% took less exercise and
38% had worse sleep
quality when on rotation

Mental health is just
the tip of the iceberg

Nutrition

Over a quarter (28%) were
less able to eat a nutritious
diet

Risky behaviours

4% more likely to have
unprotected sex

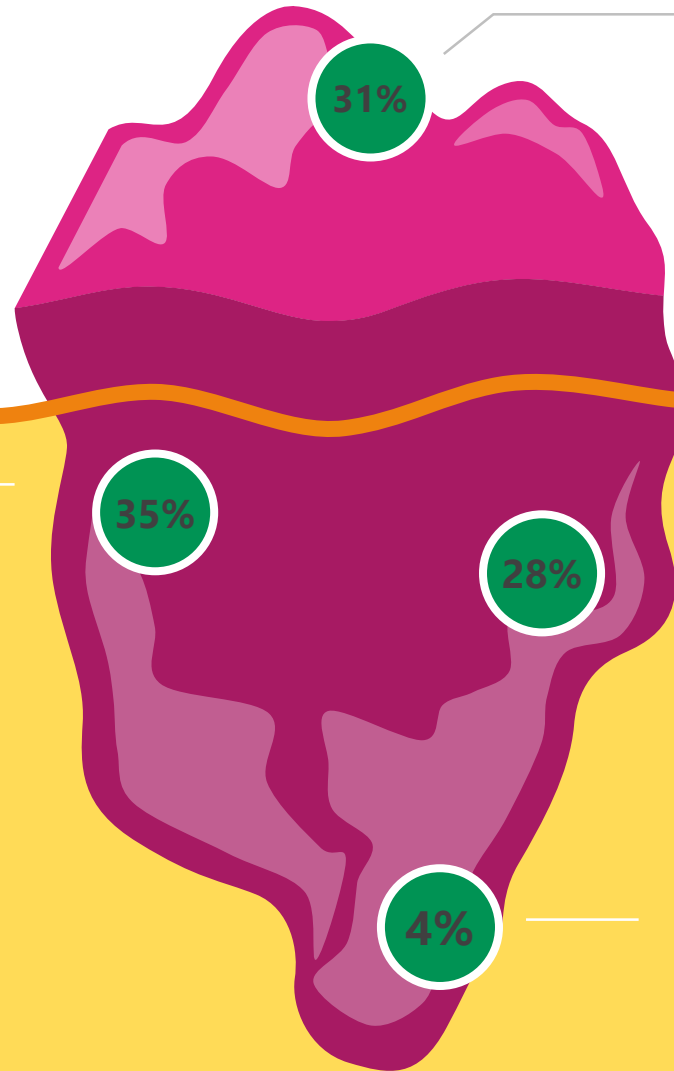



FUTURE OF TRAVEL



FUTURE OF TRAVEL

- Presenting test results & vaccine status to enable border movement will become a possibility / obligation in next 6-12 months.
- Blockchain 'passes' will grow starting with key hub airports.
- Certain domestic air routes will however remain high-risk due to limited distancing (Indonesia, Brazil).

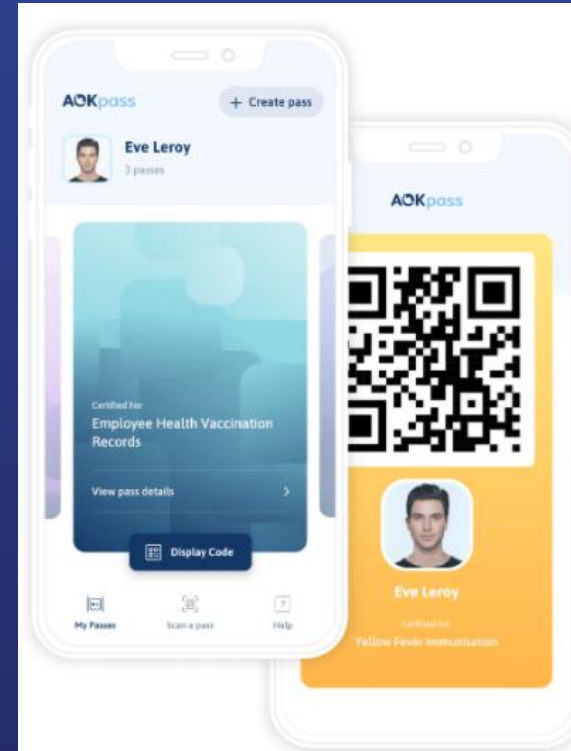

International SOS COVID Vaccine Tracker: United Arab Emirates

Country

State/Region

United Arab Emirates

All

Data last refreshed: 25/01/2021 11:20 UTC

Latest Data <h2>24/01/2021</h2>	Total Vaccinations <h2>2,487,789</h2> <p>Prev Day: 2,426,798 (+2.51%)</p>	People Vaccinated <h2>2,237,789</h2> <p>Prev Day: 2,176,798 (+2.8%)</p>	Total Vaccinations /100 <h2>25.15</h2> <p>Prev Day: 24.54 (+0.61)</p>	Daily Vaccinations (7DA) <h2>86,430</h2> <p>Prev Day: 89,839 (-3,409)</p>	% Vaccinated /day (7DA) <h2>0.87%</h2> <p>Prev Day: 0.91% (-0.03%)</p>	Weeks to 70% Pop Vacc <h2>19</h2>
Population <h2>9,890,400</h2>	People Fully Vaccinated <h2>250,000</h2> <p>Prev Day: 250,000 (+0%)</p>	People Fully Vacc /100 <h2>2.53</h2> <p>Prev Day: 2.53 (+0.00)</p>				

OWID Vaccine Location Data

Attribute	Information
last_observation_date	1/24/2021
source_name	National Emergency Crisis and Disaster Management Authority
source_website	https://covid19.ncema.gov.ae/en
vaccines	Pfizer/BioNTech, Sinopharm

Vaccine Brand

- COVAX Facility (GAVI)
- Gamaleya [Sputnik V]
- Pfizer & BioNTech [BNT1...
- Sinopharm / BIBP [BBIBP-...

Vaccine Programme

Attribute	Sinopharm / BIBP [BBIBP-CorV]
% cover per regimen	0
Approval?	Approved
Current Priority Groups	

News & Links

Attribute	Link
IntISOS Pandemic Website	https://pandemic.internationalsos.com/countries/United Arab Emirates
Procurement News Official	https://www.wam.ae/en/details/1395302893589

Country	IntISOS Pandemic Status	# Cases	New Case 7DA	Vaccine Programme Start	% Vaccine Coverage (purchased)	Vaccines Available Now	Current Priority Groups	Latest # Vaccs	Latest % Vacc /day (7DA)	People Fully Vacc/100	Weeks to 70% Vacc	Vacc vs Case Grip Ratio
Zambia	Outbreak	47,622	1,158									
Zimbabwe	Outbreak	32,004	476									
Israel	Outbreak	617,168	7,363	20/12/2020	166%	MD, P/BN	Priority Group 2	4,146,005	2.10%	15.92	6	14.77
Seychelles	Increasing Activity	1,116	53	10/01/2021		SPH		19,889	1.49%		12	
United Arab Emirates	Outbreak	285,147	3,561	23/12/2020		P/BN, SPH		2,677,680	0.88%	2.53	18	0.00
United Kingdom	Outbreak	3,700,268	31,923	08/12/2020	280%	Ox/AZ, P/BN	Priority Group 1	7,325,773	0.55%	0.70	34	0.07
Serbia	Outbreak	387,206	1,630	30/12/2020	13%	P/BN, SPH		310,266	0.57%		34	
Iceland	Decreasing Activity	5,992	3		141%	MD, P/BN		15,220	0.38%	1.40	51	206.70
Bahrain	Outbreak	100,689	347	25/12/2020		P/BN, SPH		144,130	0.36%		52	
United States	Outbreak	25,443,699	166,384	14/12/2020	198%	MD, P/BN	Priority Group 1	23,540,994	0.34%	1.05	56	1.19
Malta	Outbreak	16,999	151	27/12/2020		P/BN	Priority Group 1	21,172	0.26%		73	
Romania	Outbreak	715,438	2,506	27/12/2020		P/BN	Priority Group 1	528,378	0.19%	0.21	102	2.06
Switzerland	Outbreak	515,483	1,899	23/12/2020	92%	P/BN		197,368	0.17%		114	
Finland	Decreasing Activity	43,120	343	27/12/2020		P/BN	Priority Group 1	117,007	0.16%	0.13	125	2.76
Ireland	Outbreak	189,851	1,859	29/12/2020	9%	P/BN		143,000	0.14%		138	
Greece	Decreasing Activity	153,226	538	27/12/2020		P/BN	Priority Group 1	195,783	0.14%	0.12	140	3.02
Portugal	Outbreak	653,878	12,417	26/12/2020	108%	P/BN	Priority Group 1	263,499	0.14%		145	
France	Outbreak	3,138,498	20,245	27/12/2020	153%	P/BN	Priority Group 1	1,184,510	0.13%		151	
Cyprus	Outbreak	30,252	137	27/12/2020	149%	P/BN	Priority Group 1	17,379	0.12%	0.23	169	2.04
Germany	Outbreak	2,164,043	13,204	27/12/2020	33%	MD, P/BN	Priority Group 1	1,921,689	0.11%	0.34	174	2.58
Belgium	Outbreak	696,642	2,199	28/12/2020	122%	P/BN	Priority Group 1	213,301	0.11%	0.01	184	0.04
Poland	Outbreak	1,482,722	5,560	27/12/2020		P/BN	Priority Group 1	776,987	0.11%	0.20	185	1.76
Czechia	Outbreak	946,946	6,778	27/12/2020	42%	P/BN, MD	Priority Group 1	222,450	0.10%	0.16	196	0.25
Slovenia	Outbreak	159,812	1,239	27/12/2020		P/BN	Priority Group 1	57,591	0.10%	0.38	197	0.86
Spain	Outbreak	2,629,817	37,011	27/12/2020	61%	MD, P/BN	Priority Group 1	1,291,216	0.10%	0.26	197	0.42
Singapore	Limited Activity	59,366	30	30/12/2020		P/BN		60,000	0.09%		216	
Luxembourg	Outbreak	49,852	125	28/12/2020	104%	P/BN	Priority Group 1	8,554	0.09%	0.20	218	1.35

following categories:

re (3 months from taking the

ne vaccine.

tline workers. Ongoing

COVID-19: SWISS CHEESE MODEL

Layers of protection against COVID-19



SARS-CoV-2

Virus

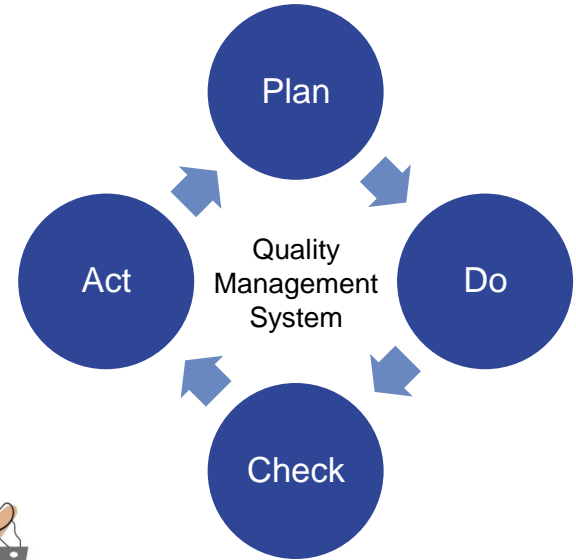
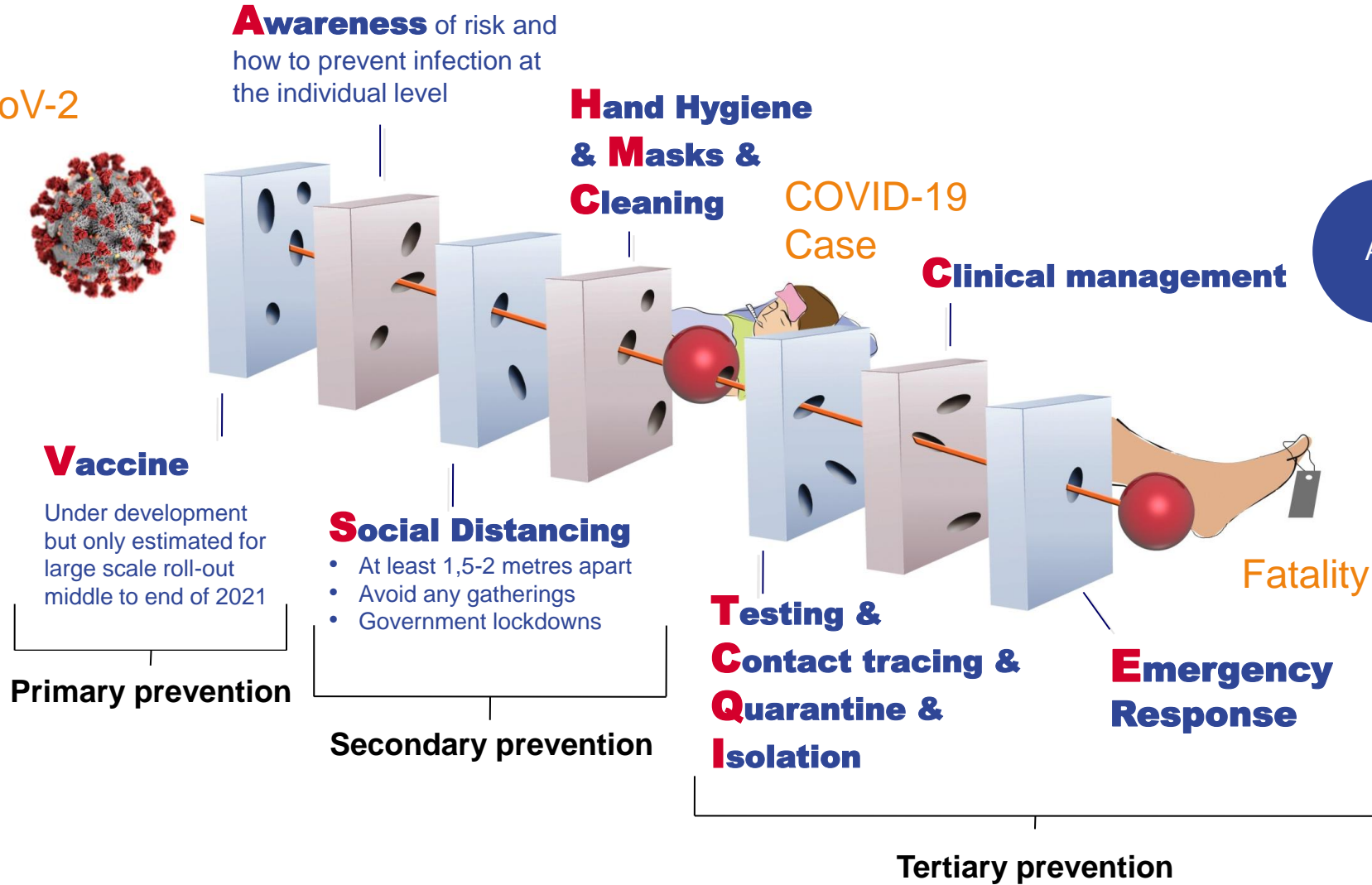
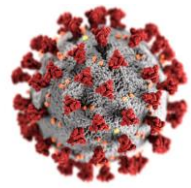

THANK YOU FOR ATTENDING

For any further enquiries, please contact:
northerneurope@internationalsos.com



[HTTPS://PANDEMIC.INTERNATIONALSOS.COM/2019-NCOV](https://pandemic.internationalsos.com/2019-ncov)

[HTTPS://MY.INTERNATIONALSOS.COM/RETURN_TO_OPERATIONS?](https://my.internationalsos.com/return_to_operations?)